

MAB 500

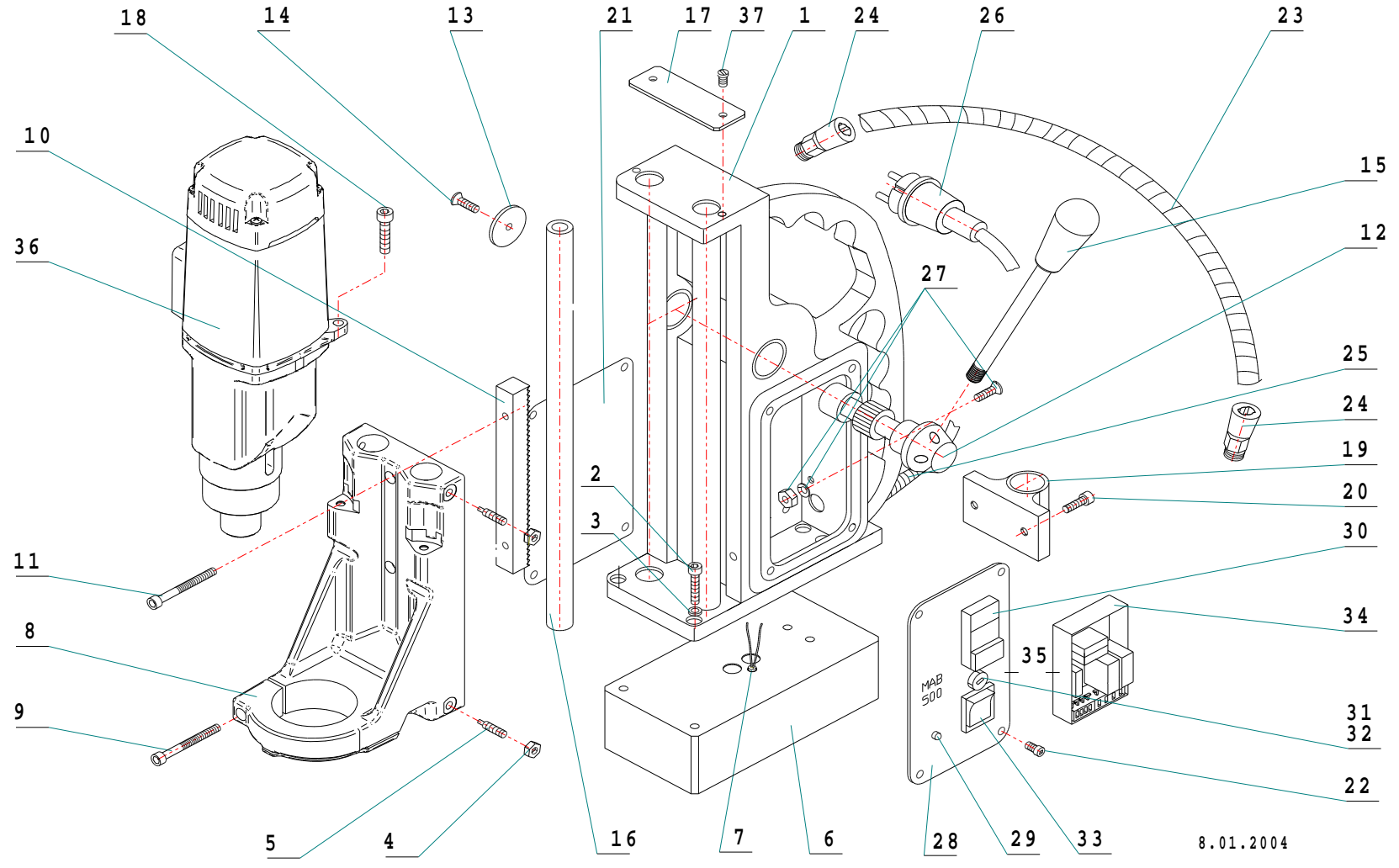

8.01.2004

Item No.	Part.-No.	Denomination
1	60 1096 1	Housing for pillar guide M8
2	60 1062 1	Screw M8x25
3	60 1057 1	Washer 8,3
4	60 1097 1	Fixing nut M8
5	60 1098 1	Srew M8X16 for slide
6	60 1099 1	Magnet (electric) with indicator
7	60 1006 1	Magnet indicator
8	60 1100 1	Slide for pillar guide
9	60 1101 1	Fixing screw for slide M6x70
10	60 1102 1	Tooth rack length: 150 mm
11	60 1046 1	Screw for tooth rack M6x30
12	60 1053 1	Shaft for gear wheel
13	60 1022 1	Disc for gear wheel
14	60 1023 1	Screw for gear wheel M6x16
15	60 1054 2	Handle rod with knob
16	60 1103 1	Pillar guide Ø 21 mm
17	60 1104 1	Cover for pillar guide
18	60 1105 1	Screw for motorfixing M8x25
19	60 1058 1	Magnet release assembly
20	60 1059 1	Screw M8x16
21	70 1085 1	Side plate
22	70 1008 1	Srew for side plate M4x6
23	70 1000 1	Cable protecting tube
23 A	70 1001 1	Cable protection tube complete with gland and cable
24	70 1002 1	Gland PG 9
25	70 1003 1	Mains cable gland PG 11
26	70 1004 1	Connection cable 220 - 240 V with plug
26 A	70 1041 1	Connection cable 220 - 240 V with English plug
26 B	70 1005 1	Connection cable 110 V (plug on demand)
27	70 1006 1	Earth screw
28	70 1086 2	Switch plate for indicator (from January 2002)
29	70 1010 1	LED-display for indicator red / green
30	70 1011 1	Actuator
31	70 1012 1	Fuse holder
32	70 1013 1	Fuse 2A, 5x20, 250 V F, DIN 41 661
33	70 1014 1	Magnet switch
34	70 1015 2	PC board with 3 Relais 230 V
34 A	70 1068 2	PC board with 3 Relais 110 V
35	70 1087 2	Switch plate complete with switches and PC board 230 V

Item No.	Part.-No.	Denomination
35 A	70 1088 2	Switch plate complete with switches and PC board 110 V
36	50 0500 2	Motor MAB 500 230 V complete
36 A	50 0510 2	Motor MAB 500 110 V complete
37	60 1052 1	Screw for cover M4x6

MAB 500 / 2002
1600W

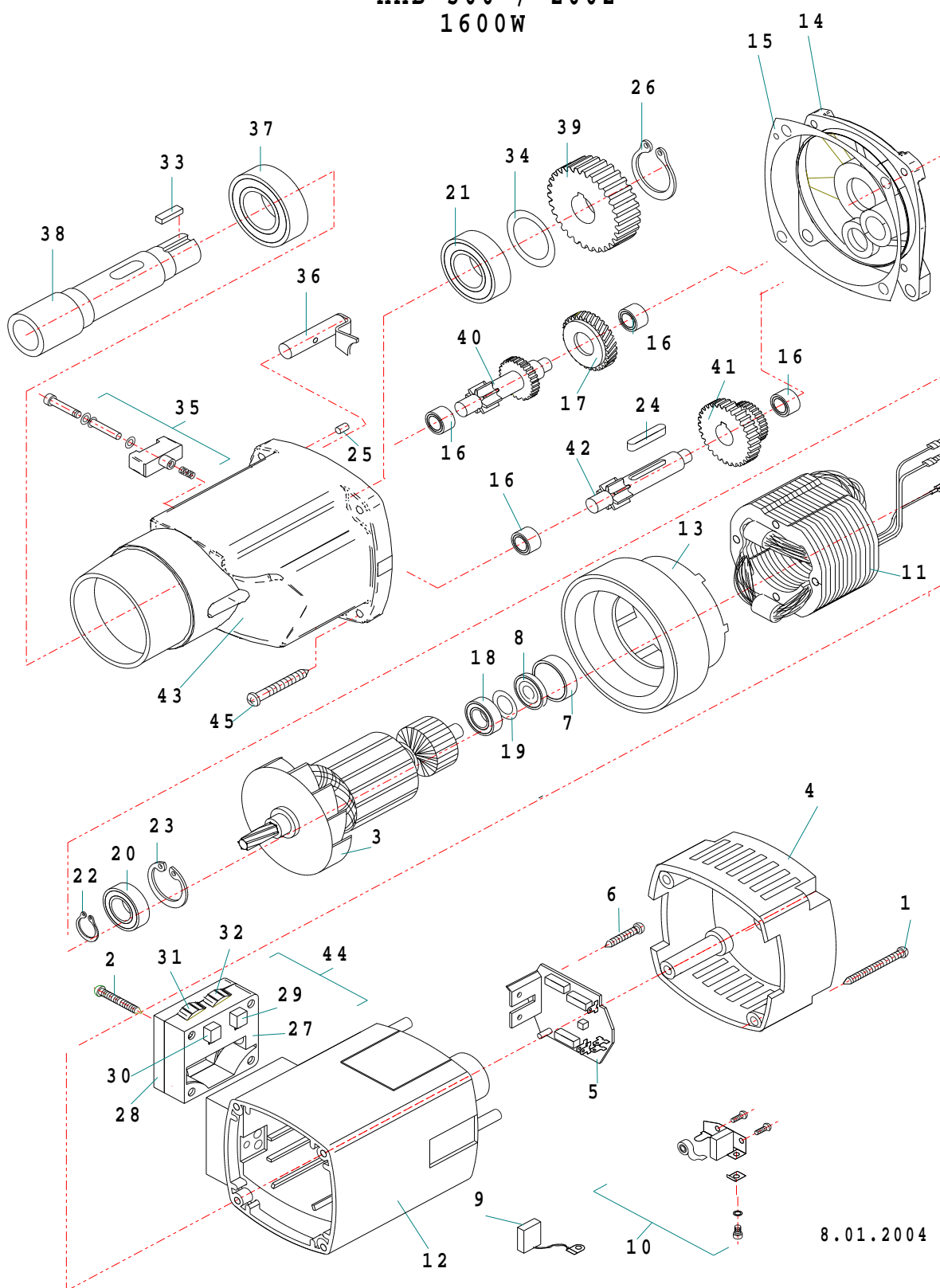

8.01.2004

Item No.	Part.-No.	Denomination
1	50 1058 1	Screw 4,8 x 45
2	50 1091 1	Screw 5,5 x 38
3	50 1219 1	Armature 220 - 240 V
3 A	50 1220 1	Armature 110 V
4	50 1153 1	Cap for Motor housing
5	50 1154 1	PC board for motor 220 V
5 A	50 1155 1	PC board for motor 110 V
6	50 1095 1	Screw 3,9 x 9,5
7	50 1156 1	Bearing cap
8	50 1157 1	Magnet ring
9	50 1158 1	Carbon brush 6,2 x 16
10	50 1160 1	Carbon brush holder complete
11	50 1221 1	Field coil 220 - 240 V
11 A	50 1222 1	Field coil 110 V
12	50 1223 1	Motor housing
13	50 1224 1	Air conducting ring
14	50 1225 1	Shield plate
15	50 1226 1	Gear box gasket
16	50 1035 1	Needle bearing HK 0810
17	50 1227 1	Intermedium gear wheel
18	50 1130 1	Ball bearing 6000 2Z
19	50 1174 1	Pressboard washer
20	50 1250 1	Ball bearing 6001 2RS
21	50 1228 1	Ball bearing 6004 2RS
22	50 1071 1	Circlip ring 11/1
23	50 1027 1	Safety ring 28/1,2
24	50 1050 1	Spring A5x5x28
25	50 1148 1	Pin 5x16
26	50 1229 1	Circlip ring 20/1,2
27	50 1166 1	Housing for potentiometer
28	50 1167 1	Cover for potentiometer
29	50 1140 1	Potentiometer for speed control 100 kOhm 2V
30	50 1168 1	Potentiometer for power control 1 kOhm 7V
31	50 1170 1	Adjustment wheel red for power control 7V
32	50 1086 1	Adjustment wheel blue for speed control 2V
33	50 1230 1	Spring A6x6x11
45	50 1231 1	Screw 6x45 black
34	50 1232 1	Washer 20 x 28 x 0,1
35	50 1234 1	Gear switch complete

Item No.	Part.-No.	Denomination
36	50 1235 1	Coupling bolt complete
37	50 1233 1	Ball bearing 6006 2RS
38	50 1236 1	Spindle with groove
39	50 1237 1	Spindle gear wheel
40	50 1238 1	Shaft for 2 gear wheels
41	50 1239 1	Gear wheel block
42	50 1240 1	Shaft for gear wheel
43	50 1241 1	Gear box case
44	50 1198 1	Housing for potentiometer